

# Flexible IT Networking: An Emerging Trend

By Peter Sevcik and Rebecca Wetzel

January 2010

The emergence of *Flexible Information Technology Networking* (Flex-IT Networking) is about to address inflexibility caused by reliance on a single carrier for an internal enterprise network. Flex-IT Networking is poised to shift the balance of power from network service providers to the enterprise.

But before we dive into the details of Flex-IT Networking, let us explain the larger concept of Flexible IT. We call it “Flexible” IT because Flex-IT solutions provide choices in many dimensions. That freedom of choice empowers enterprises to innovate and to lower costs. Flex-IT solutions are:

- Standardized,
- Available from multiple sources,
- Subject to competition,
- Ubiquitous, and
- Scalable from very small to very large.

Although the term is new, Flex-IT solutions are not. For example, computing hardware became a Flex-IT solution when the PC became a standardized, competitive, ubiquitous platform usable for devices as small as laptops and as large as blade servers. Similarly, many software platforms are becoming Flex-IT solutions through the use of standardized open source. Flex-IT is most effective and fraught with potential when individual Flex-IT components are aggregated—such as when open source software runs on a PC.

Flex-IT is just now emerging on the enterprise wide area networking scene. Recently enabled by the convergence of a number of capabilities, *Flex-IT Networking is the ability to deliver IT services over the wide area network using a mosaic of network transport options*. The resulting solution leverages the best of private and public network infrastructure to improve efficiency and reliability, save money, and adapt easily to evolving needs.

Flex-IT Networking is revolutionary because it not only enables computing resources to be delivered reliably where and when needed, it also opens up a completely new world of network transport options that free you from the expense and hegemony of single-carrier solutions by allowing you to use inexpensive Internet services to replace or complement MPLS services.

NetForecast Report  
NFR5102

©2010  
NetForecast, Inc.

---

## Flex-IT Networking at a Glance

Flex-IT Networking allows the blending of shared and dedicated server, data center, and network resources in almost any combination to meet an enterprise's needs. It is made possible by combining WAN optimization, server virtualization, and carrier-neutral colocation, with an emerging capability called *integrated transport* that uses public Internet connections to augment and/or replace dedicated private network connections (see Figure 1).

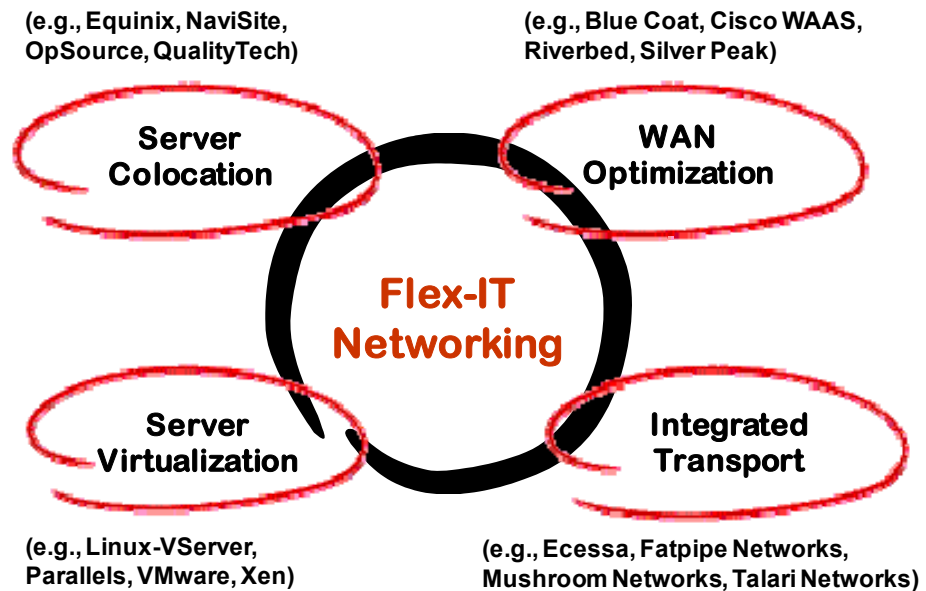

Figure 1 - Flex-IT Networking Components

---

## Flex-IT Networking Components

Three Flex-IT Networking components are well established. Carrier-neutral server colocation and WAN optimization are old hat for many enterprises—and server virtualization is fast becoming main stream. These established standalone capabilities are important in their own right, but adding the newly emerging integrated transport to the mix provides the final ingredient needed to create Flex-IT Networking, and makes the whole much more powerful than the sum of its constituent parts.

*A carrier-neutral colocation facility* is a secure data center in which multiple customers place network, server, and storage equipment that they interconnect to their choice of network service providers. Today it is most often used to house Internet-facing applications and for disaster recovery functions.

*WAN optimization* employs technology on each end of a WAN link to see, prioritize and accelerate traffic. The technology can take the form of a physical device or software on the content server.

*Server virtualization* is a technology that partitions a single server so it appears as multiple “virtual” servers. Among virtualization’s many benefits are the

increased flexibility it brings to server hardware choices, and the reduction in physical hardware needed. Reducing a server's footprint is particularly important when deploying servers at a colocation facility where real estate is expensive.

**Integrated transport** is the ability to flexibly connect geographically dispersed enterprise locations via a combination of private and virtual private network links as well as the public Internet (see Figure 2).

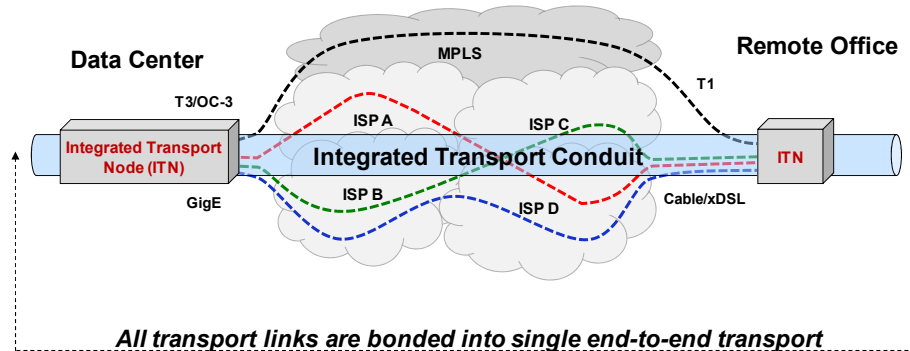

**Figure 2 - Integrated Transport – Conceptual View**

Integrated transport aggregates bandwidth from different network service providers into a single high-quality transport conduit. Underlying networking options can include MPLS, cable-based Internet access service, DSL-based Internet service, and Internet backbone service. In fact, any IP wide area service can qualify.

Integrated transport nodes provide independent conduits between enterprise locations in a mesh configuration. Of course conduit quality of service must be high for integrated transport to support enterprise applications.

Integrated transport delivers more than just the aggregation of bandwidth supplied by each underlying network, it also provides the following benefits:

**Low-cost Bandwidth:** The bandwidth available for a conduit is governed by the local bandwidth supplied to the two communicating sites. Enterprises can purchase their choice of bandwidth options from expensive or inexpensive sources. This enables an enterprise to dramatically lower per-bit costs by adding less expensive Internet services to the bandwidth mix. Such flexibility was missing from previous solutions, which lock enterprises into exclusive service provider relationships.

**High Availability:** Each integrated transport conduit can manage traffic over the multiple underlying networks. Overall availability for integrated transport solutions is higher than a single service provider solution because a conduit leverages the redundancy and availability of all the networks.

**Consistent Performance:** Some integrated transport solutions deliver latency, jitter, and loss within defined bounds. Latency is governed by

the physical distance between conduit end points; however, the underlying packet networks operate within a wide range of traffic and resource conditions which deliver service quality with a wide statistical variance. An integrated transport system should actively manage traffic across the underlying networks to reduce variance in latency, jitter, and loss to acceptable levels.

**Service Classes:** The features mentioned above should be delivered with the choice of service levels needed for different classes of applications and/or users. The service classes should be identified with standard QoS tagging and classification mechanisms to be useful to the enterprise network.

**Performance Assurance:** Performance measurement, reporting, and management tools should give enterprises the control needed to fully use integrated transport features. The system defines service levels by class and assures that those service levels are delivered. Performance assurance reports should use easily understood, industry standard reporting methods.

---

### Today's Challenge—Network Inflexibility

In the interest of cost and efficiency, enterprises have steadily moved application servers from remote offices to centralized data centers, and have pursued data center as well as server consolidation. Traffic once limited to the remote office LAN now traverses the WAN, dramatically increasing WAN traffic loads. Concurrently, carriers have widely deployed MPLS to enable virtual private IP networks, and enterprises have embraced this ability to mesh connectivity among offices (despite the fact that MPLS prices remain stubbornly high compared to public Internet service prices). The benefits enterprises have reaped from all of these actions have come at the price of network inflexibility.

Well after data center consolidation was in full swing, servers remained in remote offices to support desktop applications that required LAN-based local services. Enterprises wanted to move these local servers into the central data center to save money, circumvent the shortage of skilled on-site staff needed to keep them operating smoothly, and to comply with Sarbanes-Oxley, HIPAA and other data management mandates, but they were unable to do so because moving LAN-based applications to a data center far from users degraded application performance to unacceptable levels.

Dual-ended WAN optimization, which came into common use around 2005, solved much of the performance problem by accelerating centralized applications to acceptable levels. WAN optimization products enabled servers to migrate en masse to central data centers further concentrating computing resources.

Server virtualization has enabled server resources to be used more efficiently, and to reduce space and power needs. Virtualization enables work done by legions of physical servers to be performed with a mere fraction of the original number of machines.

Virtualization technology makes it easier and less expensive to move applications to a colocation facility because reducing the number of physical servers reduces the amount of expensive real estate required. Because colocation facilities are carrier-neutral, they enable an enterprise to cost-effectively access all of the elements needed to move from inflexible to flexible networking. Read on to learn how to implement a Flex-IT Networking solution.

---

## Deploying Flex-IT Networking

By combining the Flex-IT Networking components of WAN optimization, server virtualization, and vendor-neutral server colocation with integrated transport, enterprises can now use DSL and cable Internet services at branch offices, and high-speed Internet connections at larger sites, data centers, and colocation facilities to achieve reliable yet low-cost, high-bandwidth access for all WAN end points.

Integrated transport enables enterprises to leverage broadband Internet services, which are many orders of magnitude cheaper than MPLS, without sacrificing service quality. With IP as a common network layer, it is easy to substitute bandwidth from an MPLS service with that from a public Internet service.

But with Flex-IT Networking, it doesn't have to be an either/or decision. Flex-IT Networking allows an enterprise to continue to use an existing carrier-provided MPLS network as well as the Internet to connect end points in a "proto-flexible" networking solution shown in Figure 3.

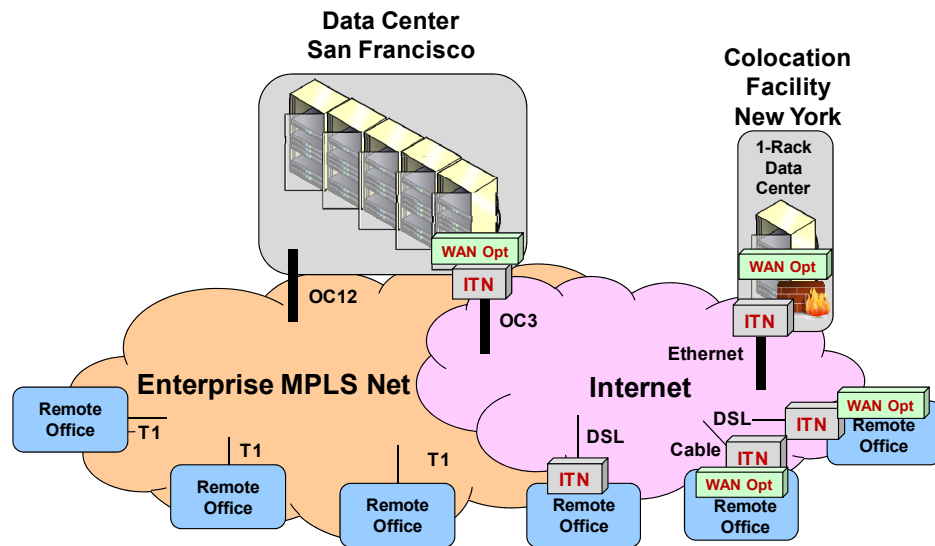

Figure 3 - "Proto-flexible" Networking Deployment

Networking groups can easily lead the way by using Flex-IT Networking to support network applications that need high reliability and resiliency. A new one-rack data center at a colocation facility can, for example, become the alternative service point for applications such as:

- Email
- Email security (spam filters, etc.)
- Exchange
- LDAP
- DNS
- DHCP
- Intrusion detection
- Firewall
- Denial of service prevention
- Storing traffic traces for future forensics or diagnostics

This list is just a sampling of applications that can now easily migrate to a colocation facility. Once the idea of Flex-IT Networking catches on, other groups within the enterprise will also want to leverage the new capabilities.

An enterprise may ultimately choose to migrate to a fully flexible IT networking solution like that shown in Figure 4. Such a fully flexible IT networking solution provides the reliability, resiliency, customer bargaining power, and cost savings that come from using a mosaic of different services from different service providers at remote offices—as well as at an enterprise’s own data center(s) and colocation facilities around the world.

In addition, such a solution also enables reliable, high bandwidth and low latency access to so-called “cloud services” by enabling an enterprise to connect to a cloud service provider directly in the same colocation facility via a direct Ethernet connection.

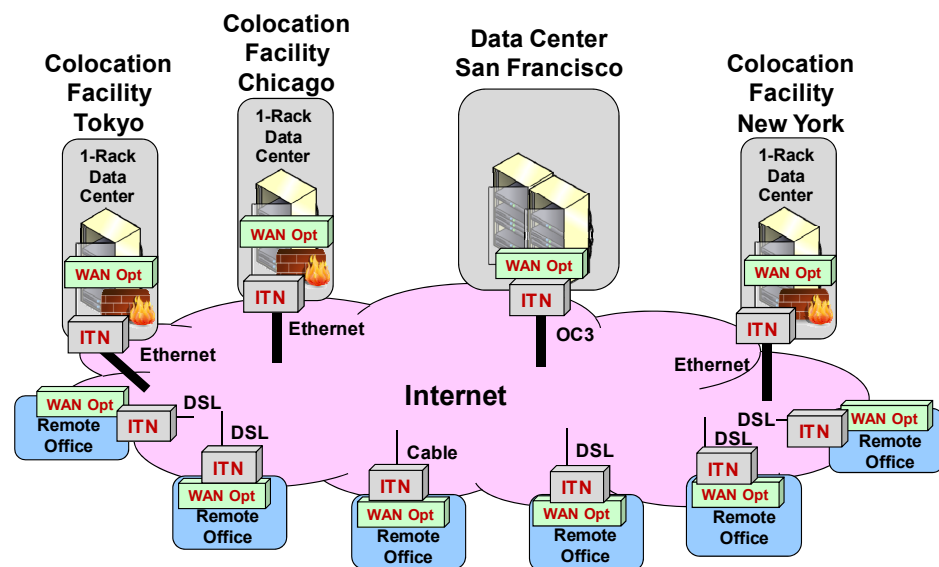

**Figure 4 - Fully Flexible IT Networking Deployment**

---

## Conclusions

Flex-IT Networking provides a reliable, resilient, and cost-effective way to deliver applications to remote users anywhere. Integrated transport makes Flex-IT Networking practical by dramatically lowering the cost of reliable private networking by enabling Internet services to replace or complement MPLS service.

You can deploy Flex-IT Networking as experimental and pilot deployments, regional deployments, as a shadow service running parallel to legacy architecture—or you can choose a full deployment that enables you to retire unneeded data centers and legacy services.

The benefits of Flex-IT Networking are myriad, and include:

- Capital and operations cost savings
- More comprehensive geographic coverage
- Better computing location redundancy
- Improved availability
- Freedom from being locked into a relationship with a single carrier
- Simplified system architecture (i.e., no distinction between users on a corporate network and the Internet)

In NetForecast's view, Flex-IT Networking is the way of the future. It makes technical as well as business sense, and will balance the relationship between network service providers and their enterprise customers. With Flex-IT Networking each enterprise is empowered to find and maintain the optimal resource and cost balance without sacrificing reliability or performance assurance.

---

## About the Authors

**Peter Sevcik** is a Principal of NetForecast and is a leading authority on Internet traffic, performance and technology. Peter has contributed to the design of more than 100 networks, holds the patent on application response-time prediction, and pioneered many performance management techniques including Apdex. At BBN Peter played a pivotal role in the development of the Internet. He can be reached at [peter@netforecast.com](mailto:peter@netforecast.com).

**Rebecca Wetzel** is a Principal of NetForecast and a veteran of the data networking industry with unparalleled inside knowledge of the Internet service and product markets. She works with network product vendors and service providers to develop and implement product strategies. She can be reached at [rebecca@netforecast.com](mailto:rebecca@netforecast.com).

NetForecast helps enterprises and vendors understand and improve the performance of networked applications.

Additional information is available at:  
[www.netforecast.com](http://www.netforecast.com)

NetForecast and the curve-on-grid logo are registered trademarks of NetForecast, Inc.